

Technical Manual
Of
Intel Bay Trail Series CPU
Based Mini-ITX M/B

NO.G03-NF9M-F

Revision: 4.0

Release date: July 20, 2017

Trademark:

- * Specifications and Information contained in this documentation are furnished for information use only, and are subject to change at any time without notice, and should not be construed as a commitment by manufacturer.

Environmental Protection Announcement

Do not dispose this electronic device into the trash while discarding. To minimize pollution and ensure environment protection of mother earth, please recycle.



TABLE OF CONTENT

ENVIRONMENTAL SAFETY INSTRUCTION	iv
USER'S NOTICE	v
MANUAL REVISION INFORMATION	v
ITEM CHECKLIST	v
CHAPTER 1 INTRODUCTION OF THE MOTHERBOARD	
1-1 FEATURE OF MOTHERBOARD	1
1-2 SPECIFICATION	2
1-3 LAYOUT DIAGRAM	3
CHAPTER 2 HARDWARE INSTALLATION	
2-1 JUMPER SETTING	8
2-2 CONNECTORS AND HEADERS	14
2-2-1 CONNECTORS	14
2-2-2 HEADERS	16
CHAPTER 3 INTRODUCING BIOS	
3-1 ENTERING SETUP	25
3-2 BIOS MENU SCREEN	26
3-3 FUNCTION KEYS	26
3-4 GETTING HELP	27
3-5 MEMU BARS	27
3-6 MAIN MENU	28
3-7 ADVANCED MENU	29
3-8 CHIPSET MENU	39
3-9 SECURITY MENU	42
3-10 BOOT MENU	43
3-11 SAVE & EXIT MENU	44



Environmental Safety Instruction

- Avoid the dusty, humidity and temperature extremes. Do not place the product in any area where it may become wet.
- 0 to 60 centigrade is the suitable temperature. (The figure comes from the request of the main chipset)
- Generally speaking, dramatic changes in temperature may lead to contact malfunction and crackles due to constant thermal expansion and contraction from the welding spots' that connect components and PCB. Computer should go through an adaptive phase before it boots when it is moved from a cold environment to a warmer one to avoid condensation phenomenon. These water drops attached on PCB or the surface of the components can bring about phenomena as minor as computer instability resulted from corrosion and oxidation from components and PCB or as major as short circuit that can burn the components. Suggest starting the computer until the temperature goes up.
- The increasing temperature of the capacitor may decrease the life of computer. Using the close case may decrease the life of other device because the higher temperature in the inner of the case.
- Attention to the heat sink when you over-clocking. The higher temperature may decrease the life of the device and burned the capacitor.

USER'S NOTICE

COPYRIGHT OF THIS MANUAL BELONGS TO THE MANUFACTURER. NO PART OF THIS MANUAL, INCLUDING THE PRODUCTS AND SOFTWARE DESCRIBED IN IT MAY BE REPRODUCED, TRANSMITTED OR TRANSLATED INTO ANY LANGUAGE IN ANY FORM OR BY ANY MEANS WITHOUT WRITTEN PERMISSION OF THE MANUFACTURER.

THIS MANUAL CONTAINS ALL INFORMATION REQUIRED TO USE THIS MOTHER-BOARD SERIES AND WE DO ASSURE THIS MANUAL MEETS USER'S REQUIREMENT BUT WILL CHANGE, CORRECT ANY TIME WITHOUT NOTICE. MANUFACTURER PROVIDES THIS MANUAL "AS IS" WITHOUT WARRANTY OF ANY KIND, AND WILL NOT BE LIABLE FOR ANY INDIRECT, SPECIAL, INCIDENTAL OR CONSEQUENTIAL DAMAGES (INCLUDING DAMAGES FOR LOSS OF PROFIT, LOSS OF BUSINESS, LOSS OF USE OF DATA, INTERRUPTION OF BUSINESS AND THE LIKE).

PRODUCTS AND CORPORATE NAMES APPEARING IN THIS MANUAL MAY OR MAY NOT BE REGISTERED TRADEMARKS OR COPYRIGHTS OF THEIR RESPECTIVE COMPANIES, AND THEY ARE USED ONLY FOR IDENTIFICATION OR EXPLANATION AND TO THE OWNER'S BENEFIT, WITHOUT INTENT TO INFRINGE.

Manual Revision Information

Reversion	Revision History	Date
3.0	Third Edition	July 29, 2014

Item Checklist

- Motherboard
- User's Manual
- CD for motherboard utilities
- Cable(s)

Chapter 1

Introduction of the Motherboard

1-1 Feature of Motherboard

- Onboard Intel® Bay Trail Series Processor, with low power consumption never denies high performance
- Support 2 * DDRIII SO-DIMM 1066/1333 MHz up to 8GB
- Support Mini-PCIE connector
- Support m-SATA connector
- Support 2 * SATAII device
- Integrated with 1 * 24-bit dual channel LVDS header
- Support DVI-I output
- Support USB 3.0 data transport demand
- Support CPU Smart FAN
- Compliance with ErP standard
- Support Watchdog function

1-2 Specification

Spec	Description
Design	<ul style="list-style-type: none">● 6 layers; PCB size: 17x 17 cm
Embedded CPU	<ul style="list-style-type: none">● Integrated with Intel[®] Bay Trail-D/M/I series CPU
Memory Slot	<ul style="list-style-type: none">● 2 * DDRIII L SODIMM Slot for un-buffered dual channel DDRIII L 1333 MHz SDRAM, expandable to 8GB in total
Expansion Slot	<ul style="list-style-type: none">● 1* full-size Mini-PCIE slot● 1* PCIE x1 slot
LAN Chip	<ul style="list-style-type: none">● Integrated with dual Realtek RTL8111G PCI-E Gigabit LAN chips● Support Fast Ethernet LAN function of providing 10/100/1000Mbps Ethernet data transfer rate
Storage	<ul style="list-style-type: none">● 2* SATAII port● 1* mSATA slot
BIOS	<ul style="list-style-type: none">● AMI 64MB Flash ROM
Rear I/O	<ul style="list-style-type: none">● 1* DC 9V~36V power-in connector● 1* USB 3.0 port● 3* USB 2.0 port● 1* DVI-I port● 1* COM port● 1* RJ-45 LAN port● Audio Line Out port x1
Internal I/O	<ul style="list-style-type: none">● 2* SATAII 3Gb/s port● 1* SATA Power connector● 1* CPU FAN header● 2* SYSFAN header ● 1* Front panel audio header● 1* SPDIF Out header● 1* SPEAK_CON header

	<ul style="list-style-type: none"> ● 1* Parallel port header ● 3* Serial port header ● 1* USB 2.0 header (Expansible to 2* USB 2.0 ports) ● 1* USB 3.0 header (Expansible to 2* USB 3.0 ports) ● 1* Power LED & speaker header ● 1* Front panel header ● 1* GPIO_CON header ● 1* PS2KBMS header ● 1* SMBUS header ● 1* LAN LED activity header ● 1* LVDS header ● 1* LVDS inverter
--	--

1-3 Layout Diagram

Rear IO Panel Diagram:

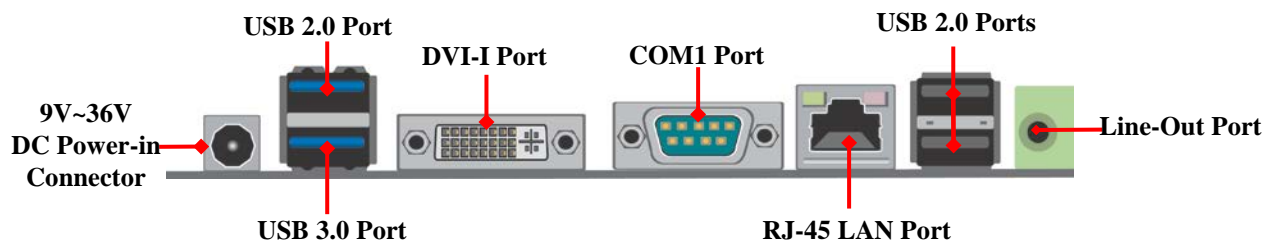

Motherboard Internal Diagram

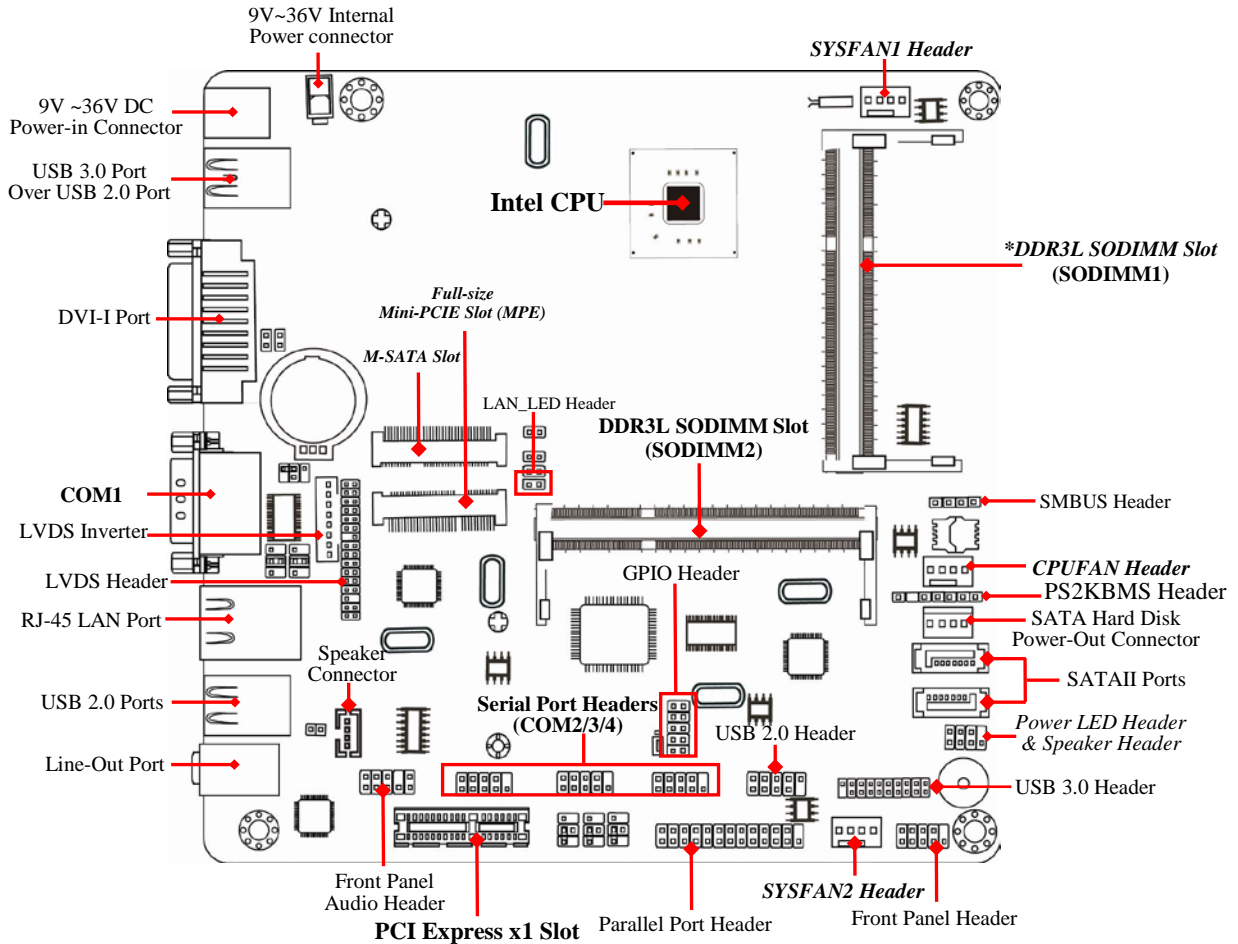

Note: 1. Priority should be given to SODIMM1 slot when installing only one compatible memory modules. 2. The module should be **DDR3L 1.35V SODIMM** and **not exceeding 8GB total capacity**.

Jumper Position:

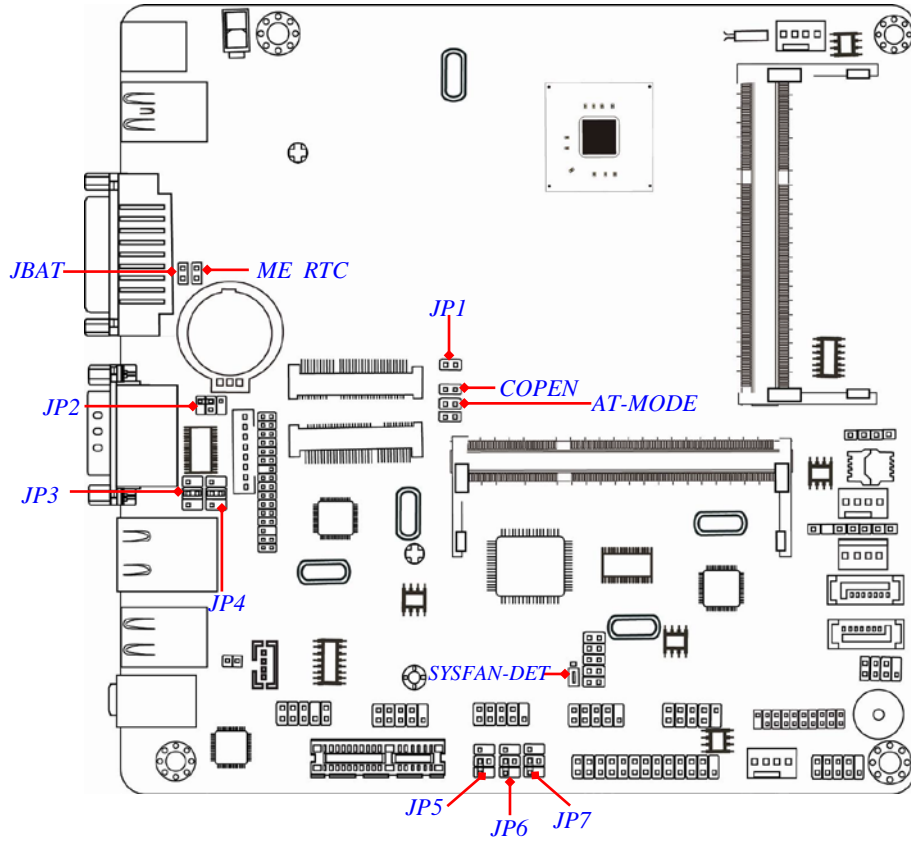

Jumper

Jumper	Name	Description
JBAT	CMOS RAM Clear Function Setting	2-Pin Block
ME_RTC	Clear ME RTC Function Setting	2-Pin Block
COPEN	Case Open Message Display Function	2-Pin Block
AT_MODE	AT Mode Function Select	2-Pin Block
SYSFAN_DET	SYSFAN1/SYSFAN2 R.P.M. Select	3-Pin Block
JP1	Security Measure Function Select	2-Pin Block
JP3	LVDS PVCC 5V/3.3V /12V Select	4-Pin Block
JP4	LCD Back Light 5V/12V/DCIN Select	4-Pin Block
JP2	COM1 Port Pin9 Function Select	4-Pin Block
JP5	COM2 Header Pin9 Function Select	4-Pin Block
JP6	COM3 Header Pin9 Function Select	4-Pin Block
JP7	COM4 Header Pin9 Function Select	4-Pin Block

Connectors

Connector	Name
DCIN	DC 9V~36V Power-in Connector
SATA1/SATA2	SATAII Port Connector
SATAPW	SATA Power out Connector
CPUFAN	CPUFAN Connector
SYSFAN1/SYSFAN2	SYSFAN Connector X2
USB20/USB30(Top)	USB 2.0 Port Connector X3
USB30(Bottom)	USB 3.0 Port Connector
LAN	RJ-45 LAN Port Connector
DVI-I	DVI-I Port Connector
COM1	Serial port
LINE_OUT	Audio Line Out Connector

Headers

Header	Name	Description
FP_AUDIO	Front Panel Audio Header	9-pin Block
SPDIF	SPDIF Out Header	2-pin Block
SPEAK_CON	Speaker Header	4-pin Block
LPT	Parallel Port Header	25-pin Block
COM2/3/4	Serial Port Header X3	9-pin Block
GPIO_CON	GPIO Header	10-pin Block
FP_USB20	USB 2.0 Header	9-pin Block
FP_USB30	USB 3.0 Header	19-pin Block
SPK-LED	Power LED & Speaker Header	7-pin Block
JW_FP	Front Panel Header(PWR LED/ HDD LED/Power Button /Reset)	9-pin Block
PS2KBMS	PS/2 Keyboard & Mouse Header	6-pin Block
SMBUS	SMBUS Header	4-pin Block
LAN_LED	LAN Activity LED Header	2-pin Block
LVDS	LVDS Header	30-pin Block
INVERTER	LVDS Inverter	8-pin Block

Chapter 2

Hardware Installation

2-1 Jumper Setting

(1) JBAT (2-pin): Clear CMOS Setting

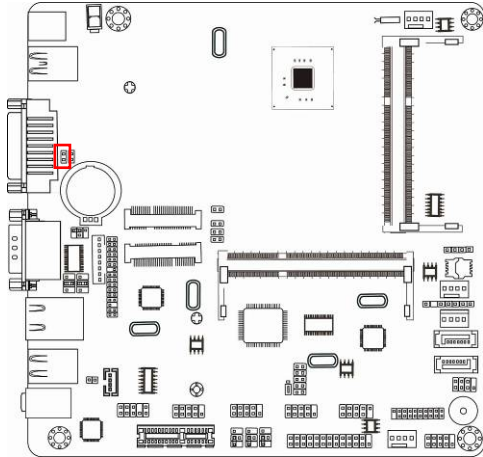

JBAT



1-2 Open: Normal;

1-2 Closed: Clear CMOS

CMOS Clear Setting

(2) ME_RTC (2-pin): Clear ME_RTC Function Setting

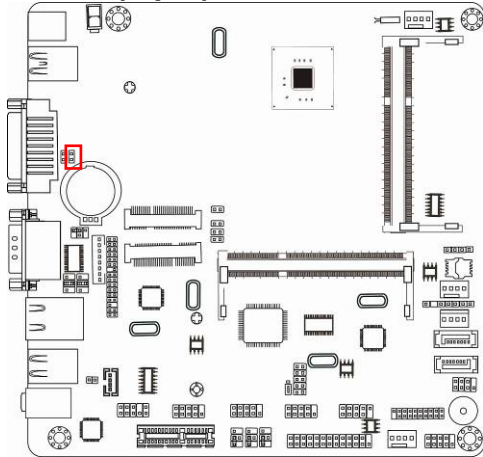

ME_RTC



1-2 Open: Normal;

1-2 Closed: Clear ME_RTC.

CMOS ME_RTC Setting

(3)COPEN (2-pin): Case Open Message Display Function Select

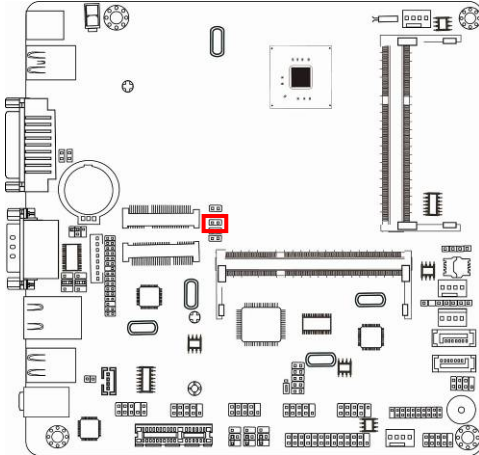

COPEN



1-2 Open: Normal;



1-2 Closed: Case Open
Function Selected (One Touch).

Pin 1-2 Closed: When Case open function pin short to GND, the Case open function was detected. When Used, needs to enter BIOS and enable 'Case Open Detect' function. In this case if your case is removed, next time when you restart your computer, a message will be displayed on screen to inform you of this.

(4)AT_MODE (2-pin): AT Mode Function Select

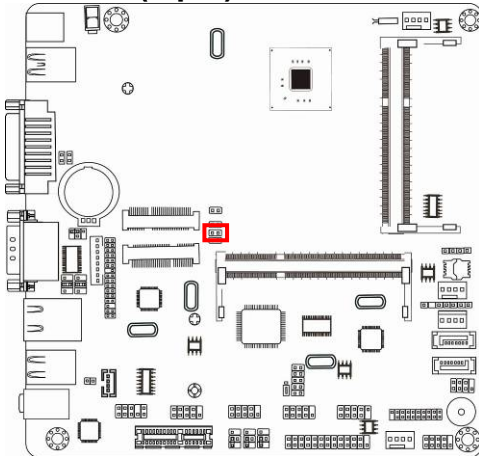

AT_MODE



1-2 Open: ATX Mode Selected;



1-2 Closed: AT Mode Selected.

Pin 1-2 closed: AT_MODE function is enabled. User needs to restart the system for the settings to take effect. In this case your computer will automatically turns on when power supply resumes.

(5) SYSFAN_DET (3-pin): SYSFAN1/SYSFAN2 R.P.M. Select

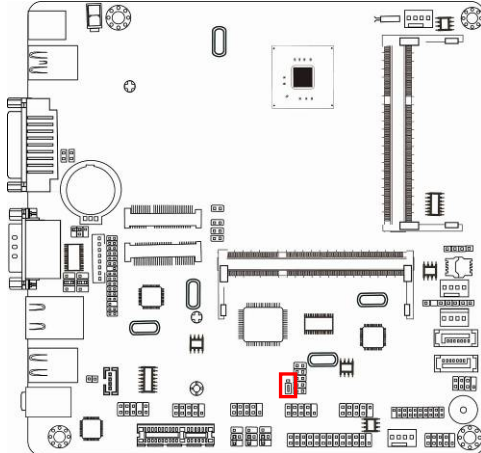

SYSFAN_DET

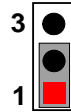

1-2 Closed:

SYSFAN1 R.P.M. Selected;

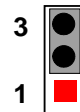

2-3 Closed:

SYSFAN2 R.P.M. Selected.

(6) JP1 (2-pin): Security Measure Function Select

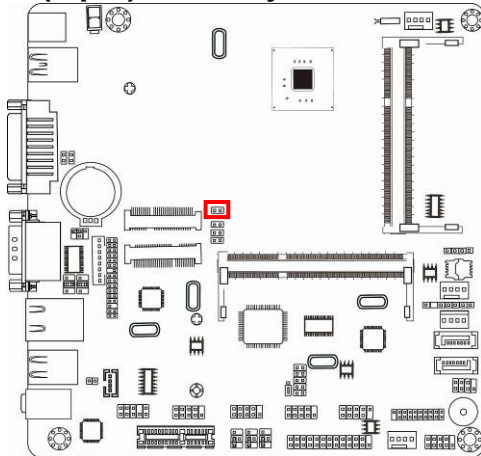

JP1



1-2 Open: Enable Security Measures in the Flash Descriptor(Default);



1-2 Closed: Disable Security Measures in the Flash Descriptor(Override).

(7) JP3 (4-pin): LVDS PVCC 3.3V/5V/12V Function Select

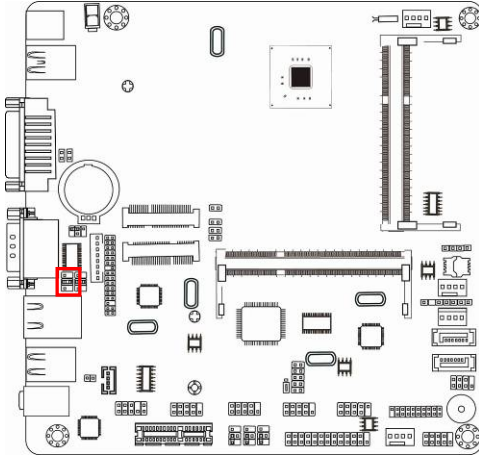

JP3→LVDS PVCC

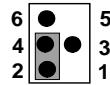

2-4 Closed:
VCC=3.3V;

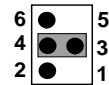

3-4 Closed:
VCC= 5V;

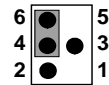

4-6 Closed:
VCC= 12V.

(8) JP4 (4-pin): LCD Back Light VCC 3.3V/5V/12V Select

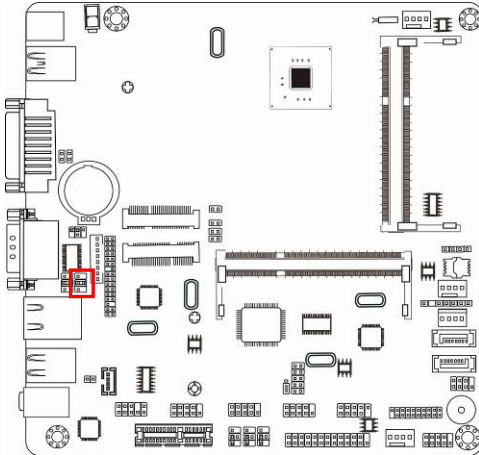

JP4→LCD Back Light

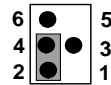

2-4 Closed:
VCC=5V;

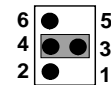

3-4 Closed:
VCC= 12V;

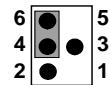

4-6 Closed:
VCC= DCIN.

(9) JP2 (4-pin): COM1 Port Pin9 Function Select

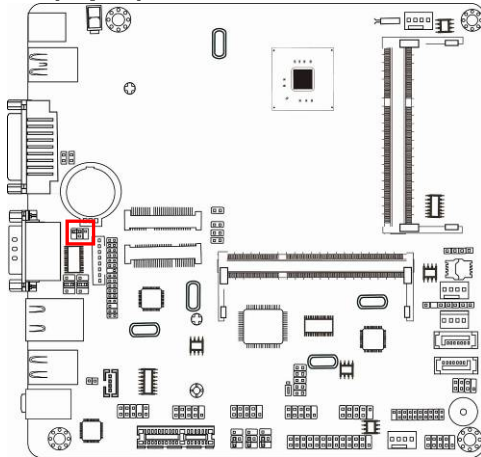

JP2→COM1

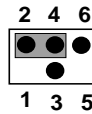

2-4 Closed:
RI=RS232;

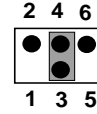

3-4 Closed:
RI= 5V;

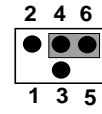

4-6 Closed:
RI= 12V.

(10) JP5 (4-pin): COM2 Header Pin9 Function Select

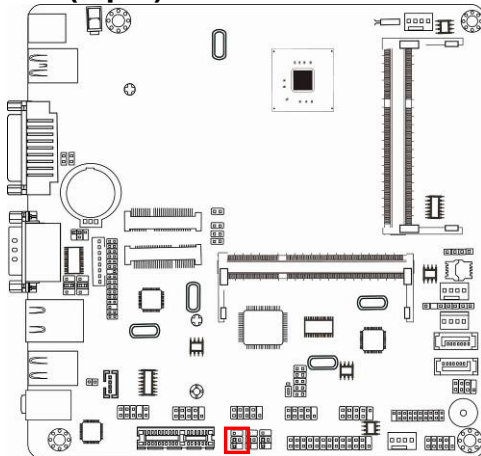

JP5→COM2 Header

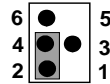

2-4 Closed:
RI=RS232;

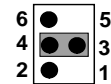

3-4 Closed:
RI= 5V;

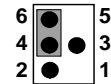

4-6 Closed:
RI= 12V.

(11) JP6 (4-pin): COM3 Header Pin9 Function Select

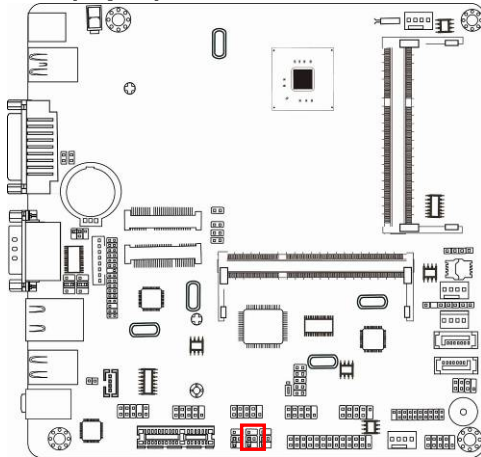

JP6→COM3 Header

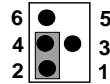

2-4 Closed:
RI=RS232;

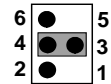

3-4 Closed:
RI= 5V;

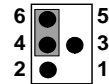

4-6 Closed:
RI= 12V.

(12) JP7 (4-pin): COM4 Header Pin9 Function Select

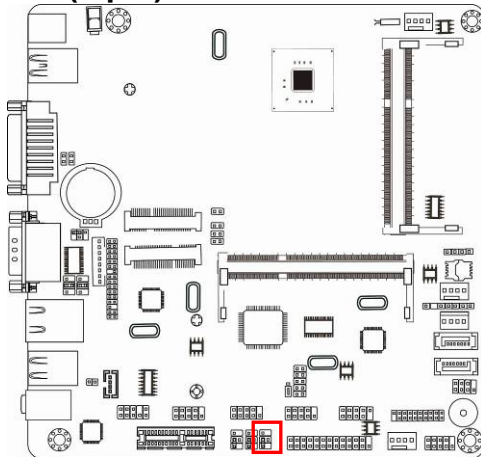

JP7→COM4 Header

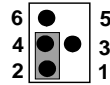

2-4 Closed:
RI=RS232;

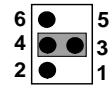

3-4 Closed:
RI= 5V;

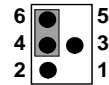

4-6 Closed:
RI= 12V.

2-2 Connectors and Headers

2-2-1 Connectors

(1) Rear I/O Connectors

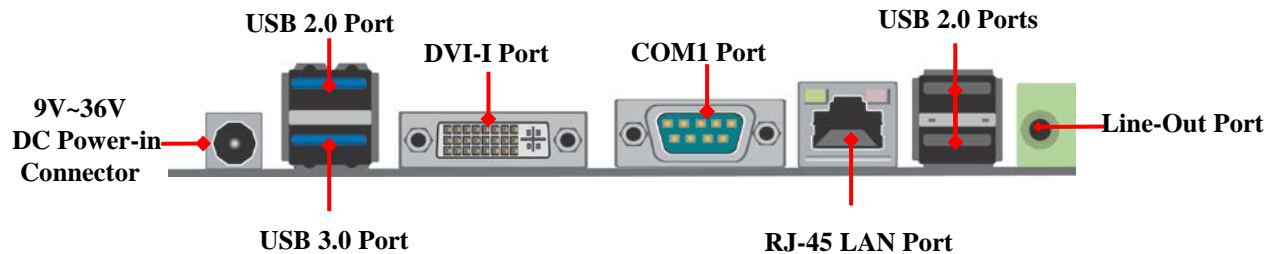

(2) COM1 (9-pin Block): RS232/422/485 Port

COM1 port can function as RS232/422/485 port. In normal settings COM1 functions as RS232 port. With compatible COM cable COM1 can function as RS422 or RS 485 port.

User also needs to go to BIOS to set '**Transmission Mode Select**' for COM1 (*refer to Page 30*) at first, before using specialized cable to connect different pins of this port.

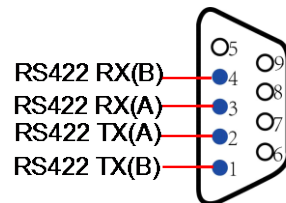

For RS422 Mode

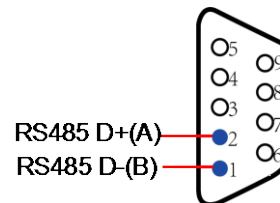

For RS485 Mode

(3) SATAII Port connector: SATA1/SATA2

These are high-speed SATAII ports that support 3GB/s transfer rate.

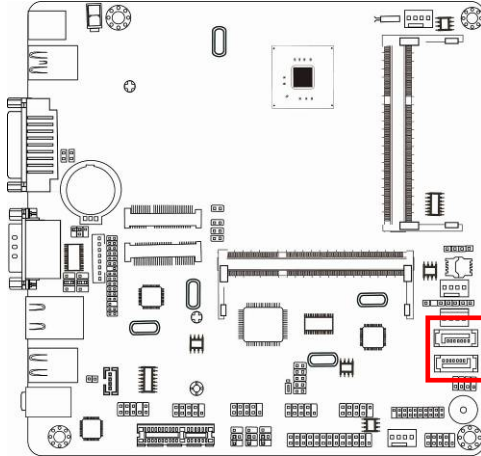

Pin No.	Definition
1	GND
2	TXP
3	TXN
4	GND
5	RXN
6	RXP
7	GND

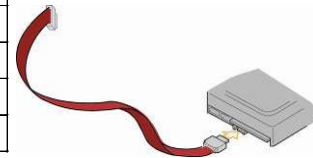

(4) SATA Power Connector (4-pin): SATAPW

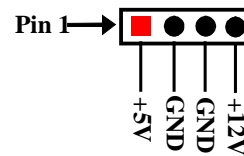
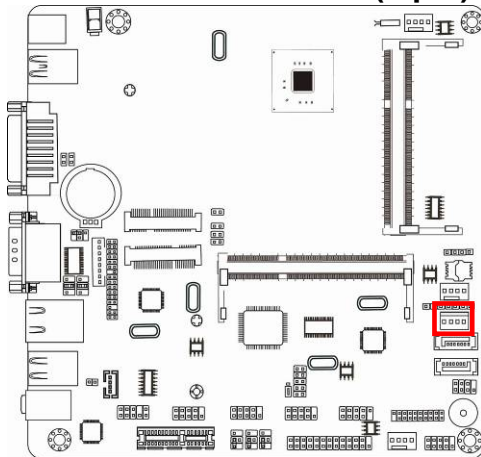

(5) CPUFAN/SYSFAN1/SYSFAN2 (4-pin): Fan Connectors

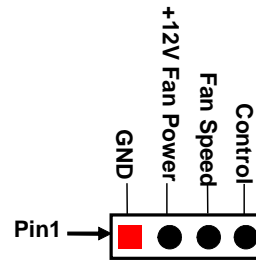
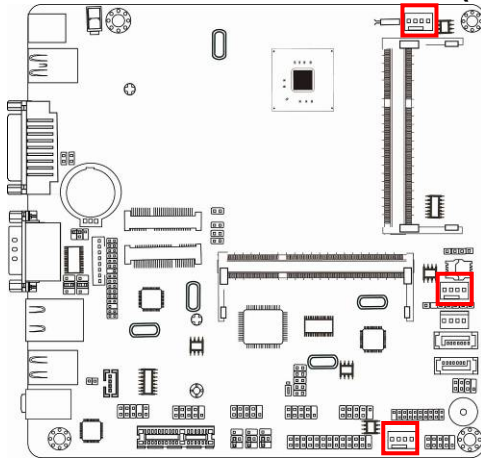

CPUFAN/ SYSFAN1/SYSFAN2

2-2-2 Headers

(1) FP_AUDIO (9-pin): Line-Out, MIC-In Header

This header connects to Front Panel Line-out, MIC-In connector with cable.

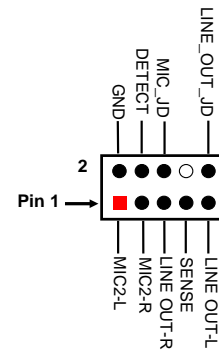
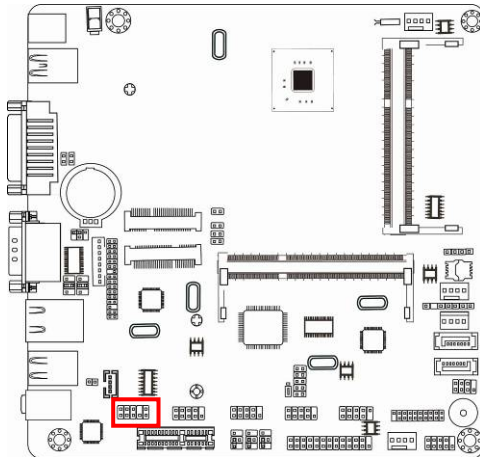

Line-Out, MIC Header

(2) SPDIF (2-pin): SPDIF Out Header

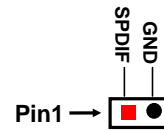
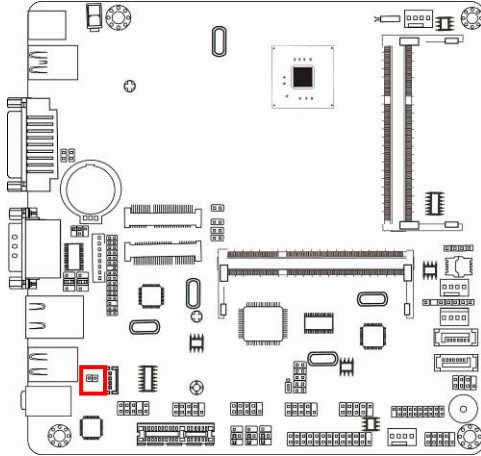

(3)SPEAK_CON (4-pin): Speaker Connector

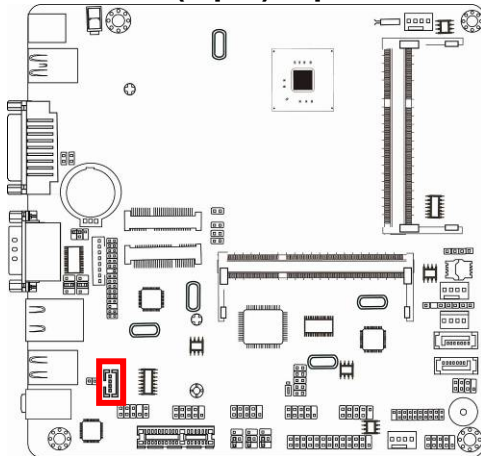

Pin No.	Definition
1	L-
2	L+
3	R+
4	R-

(4) LPT (25-pin): Parallel Port Header

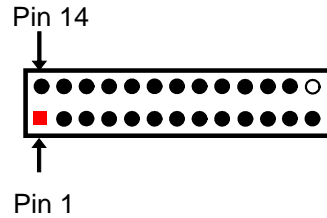
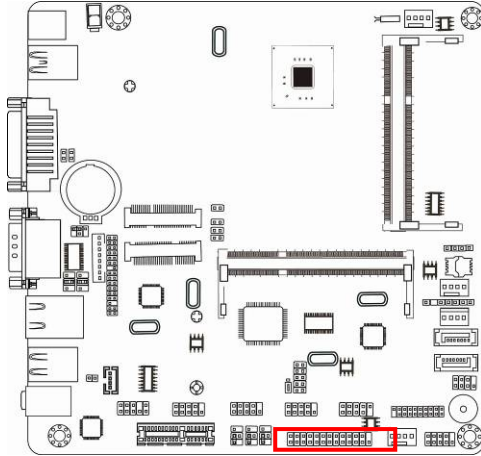

Pin NO.	Pin Definition	Pin NO.	Pin Definition
Pin 1	STB-	Pin 14	AFD-
Pin 2	PRD0	Pin 15	ERR-
Pin 3	PRD1	Pin 16	INIT-
Pin 4	PRD2	Pin 17	SLIN-
Pin 5	PRD3	Pin 18	GND
Pin 6	PRD4	Pin 19	GND
Pin 7	PRD5	Pin 20	GND
Pin 8	PRD6	Pin 21	GND
Pin 9	PRD7	Pin 22	GND
Pin 10	ACK-	Pin 23	GND
Pin 11	BUSY	Pin 24	GND
Pin 12	PE	Pin 25	GND
Pin 13	SLCT		

(5) COM2/COM3/COM4 (9-pin): Serial Port Headers

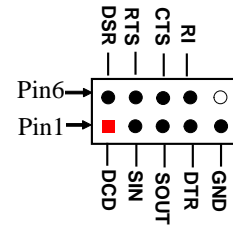
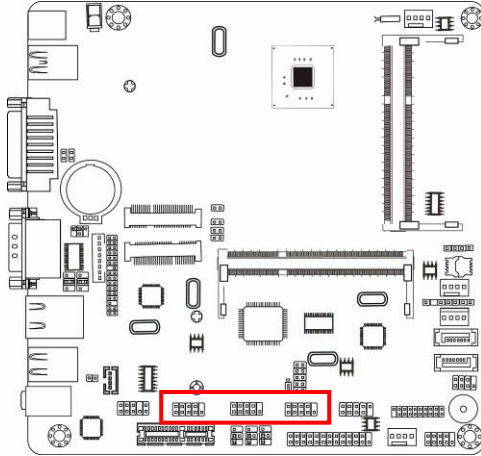

(6) GPIO_CON (10-pin): GPIO Header

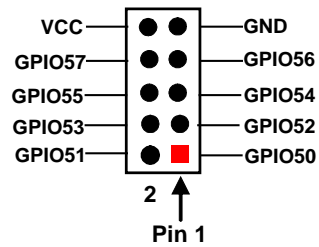
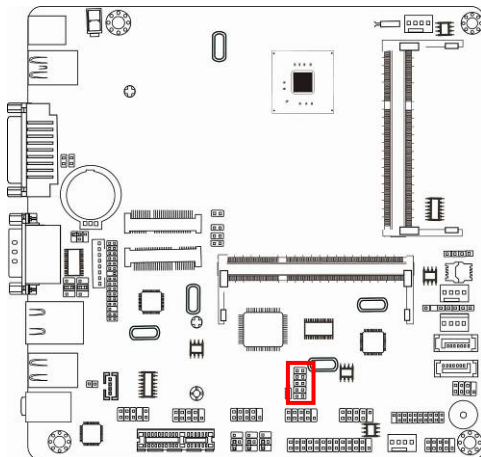

(7) FP_USB20 (9-pin): USB 2.0 Port Header

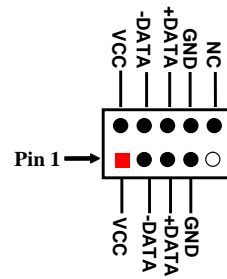
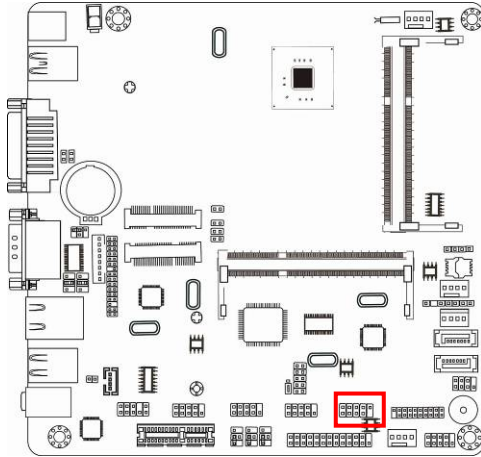

(8) FP_USB30 (19-pin): USB 3.0 Port Header

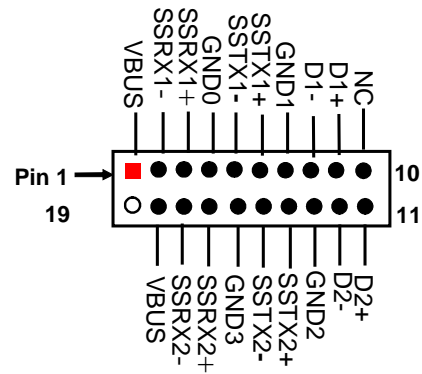
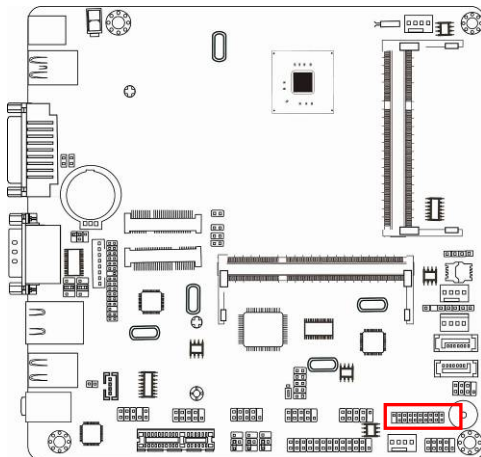

(9) SPK-LED (7-pin): Speaker Header & PWR LED Header

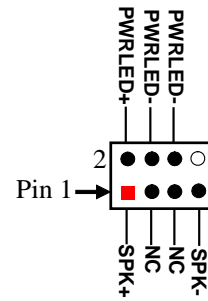
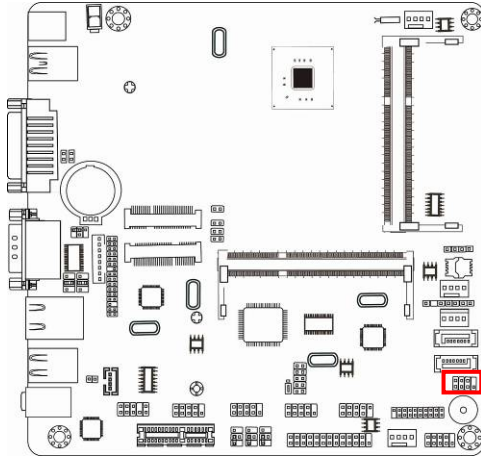

(10) JW_FP (9-pin): Front Panel Header

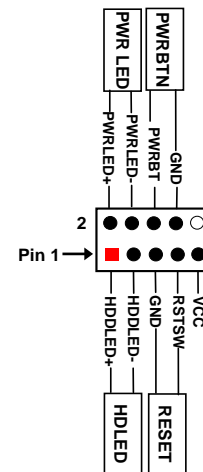
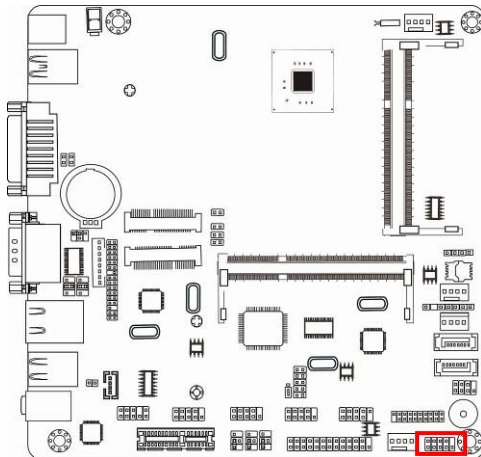

(11) PS2KBMS (6-pin): PS/2 Keyboard & Mouse Header

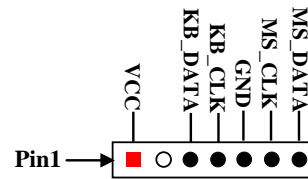
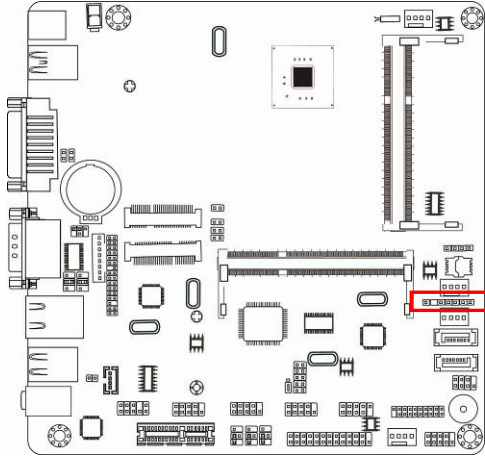

(12) SMBUS (4-Pin): SM BUS Header

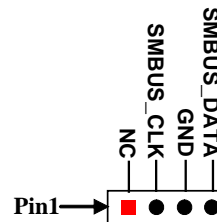
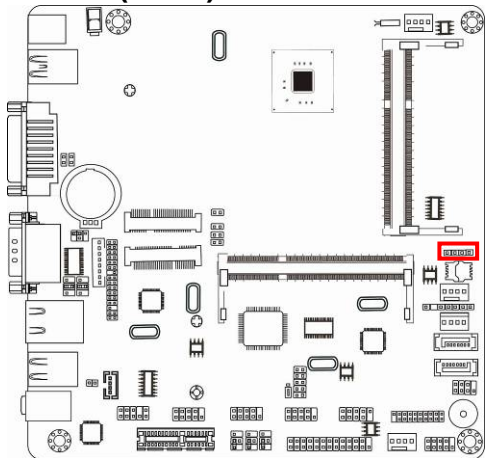

(13) LAN_LED (2-pin): LAN Activity LED Header

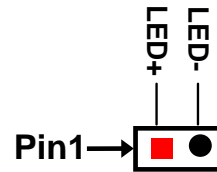
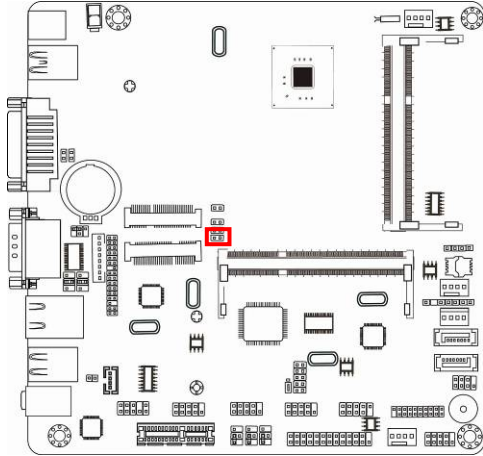

(14) LVDS (30-pin): 24-bit Dual Channel LVDS Header

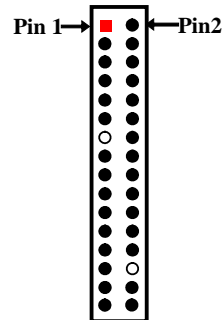
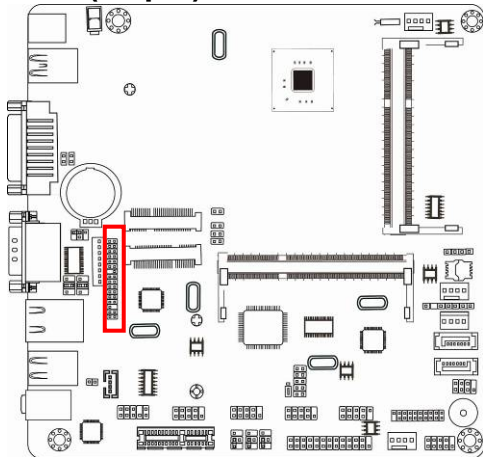

Pin NO.	Pin Define	Pin NO.	Pin Define
Pin 1	LVDSB_DATAN3	Pin 2	LVDSB_DATAP3
Pin 3	LVDS_CLKBN	Pin 4	LVDS_CLKBP
Pin 5	LVDSB_DATAN2	Pin 6	LVDSB_DATAP2
Pin 7	LVDSB_DATAN1	Pin 8	LVDSB_DATAP1
Pin 9	LVDSB_DATAN0	Pin 10	LVDSB_DATAP0
Pin 11	NC	Pin 12	NC
Pin 13	N/A	Pin 14	GND
Pin 15	GND	Pin 16	GND
Pin 17	LVDSA_DATAP3	Pin 18	LVDSA_DATAN3
Pin 19	LVDS_CLKAP	Pin 20	LVDS_CLKAN
Pin 21	LVDSA_DATAP2	Pin 22	LVDSA_DATAN2
Pin 23	LVDSA_DATAP1	Pin 24	LVDSA_DATAN1
Pin 25	LVDSA_DATAP0	Pin 26	LVDSA_DATAN0
Pin 27	PVDD	Pin 28	N/A
Pin 29	PVDD	Pin 30	PVDD
Pin 31	GND	Pin 32	GND

(15) INVERTER (8-pin): LVDS Inverter Connector

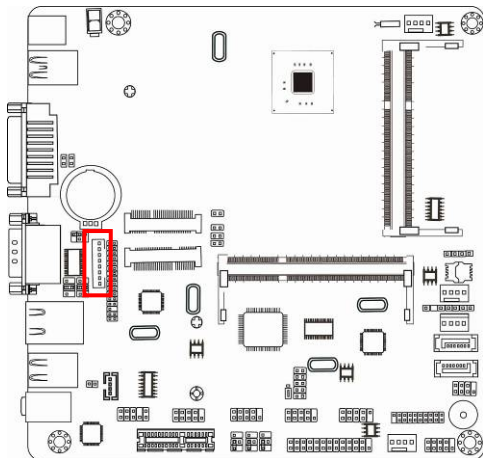

Pin No.	Definition
1	Backlight Enable
2	Backlight PWM
3	Backlight VCC
4	Backlight VCC
5	GND
6	GND
7	Backlight Up SW
8	Backlight Down SW

Chapter 3

Introducing BIOS

Notice! The BIOS options in this manual are for reference only. Different configurations may lead to difference in BIOS screen and BIOS screens in manuals are usually the first BIOS version when the board is released and may be different from your purchased motherboard. Users are welcome to download the latest BIOS version form our official website.

The BIOS is a program located on a Flash Memory on the motherboard. This program is a bridge between motherboard and operating system. When you start the computer, the BIOS program will gain control. The BIOS first operates an auto-diagnostic test called POST (power on self test) for all the necessary hardware, it detects the entire hardware device and configures the parameters of the hardware synchronization. Only when these tasks are completed done it gives up control of the computer to operating system (OS). Since the BIOS is the only channel for hardware and software to communicate, it is the key factor for system stability, and in ensuring that your system performance as its best.

3-1 Entering Setup

Power on the computer and by pressing immediately allows you to enter Setup. If the message disappears before your respond and you still wish to enter Setup, restart the system to try again by turning it OFF then ON or pressing the “RESET” button on the system case. You may also restart by simultaneously pressing <Ctrl>, <Alt> and <Delete> keys. If you do not press the keys at the correct time and the system does not boot, an error message will be displayed and you will again be asked to

Press **** to enter Setup

* When system POST boots, you may press “H” or “C” key to change display device.
Press <H> key to switch HDMI/DVI display first.
Press <C> key to switch CRT/DVI display first.

3-2 BIOS Menu Screen

The following diagram show a general BIOS menu screen:

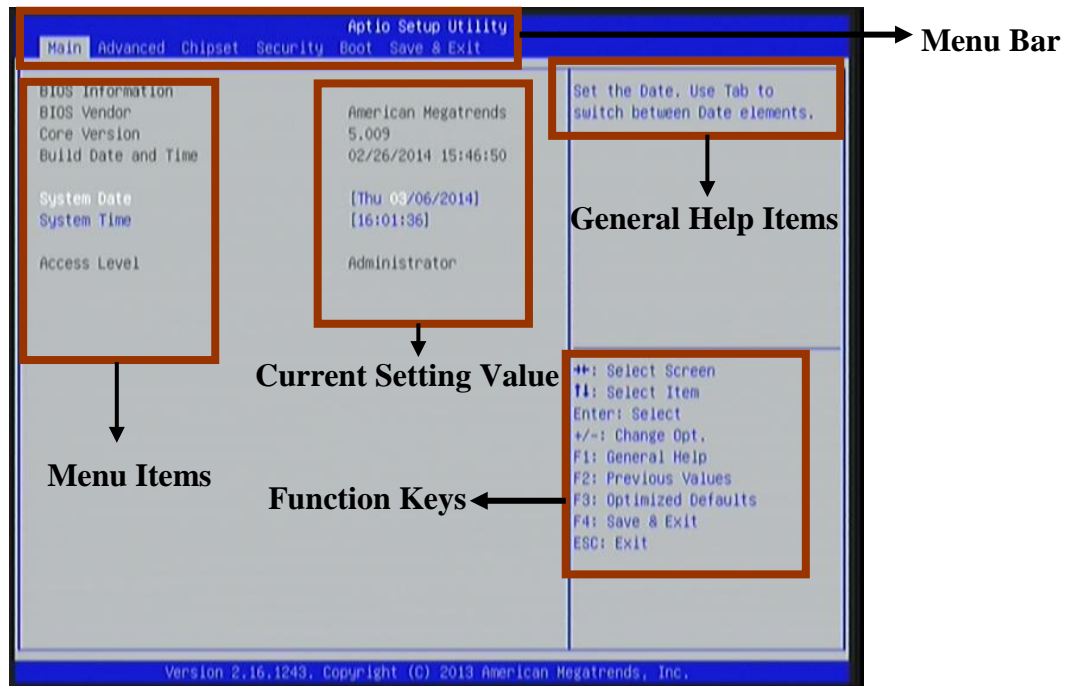

BIOS Menu Screen

3-3 Function Keys

In the above BIOS Setup main menu of, you can see several options. We will explain these options step by step in the following pages of this chapter, but let us first see a short description of the function keys you may use here:

-
-
- Press←→ (left, right) to select screen;
 - Press ↑↓ (up, down) to choose, in the main menu, the option you want to confirm or to modify.
 - Press <Enter> to select.
 - Press <+>/<-> keys when you want to modify the BIOS parameters for the active option.
 - [F1]: General help.
 - [F2]: Previous value.
 - [F3]: Optimized defaults.
 - [F4]: Save & Reset.
 - Press <Esc> to quit the BIOS Setup.

3-4 Getting Help

Main Menu

The on-line description of the highlighted setup function is displayed at the top right corner the screen.

Status Page Setup Menu/Option Page Setup Menu

Press F1 to pop up a small help window that describes the appropriate keys to use and the possible selections for the highlighted item. To exit the Help Window, press <Esc>.

3-5 Menu Bars

There are six menu bars on top of BIOS screen:

Main	To change system basic configuration
Advanced	To change system advanced configuration
Chipset	To change chipset configuration
Security	Password settings
Boot	To change boot settings
Save & Exit	Save setting, loading and exit options.

User can press the right or left arrow key on the keyboard to switch from menu bar. The selected one is highlighted.

3-6 Main Menu

Main menu screen includes some basic system information. Highlight the item and then use the <+> or <-> and numerical keyboard keys to select the value you want in each item.

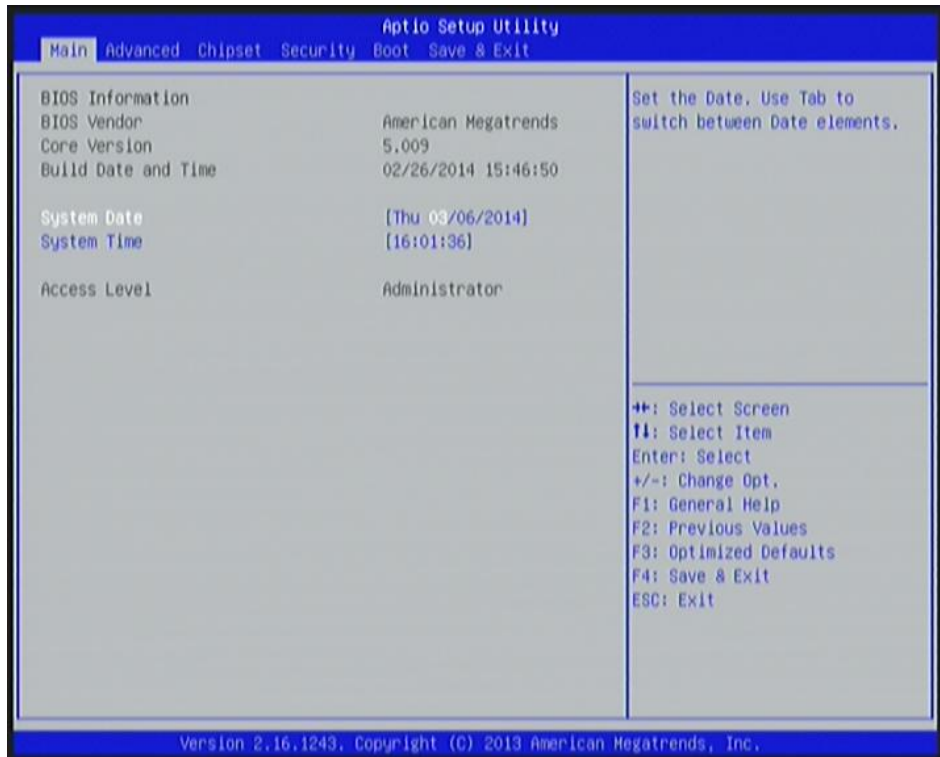

System Date

Set the date. Please use [Tab] to switch between data elements.

System Time

Set the time. Please use [Tab] to switch between time elements.

3-7 Advanced Menu

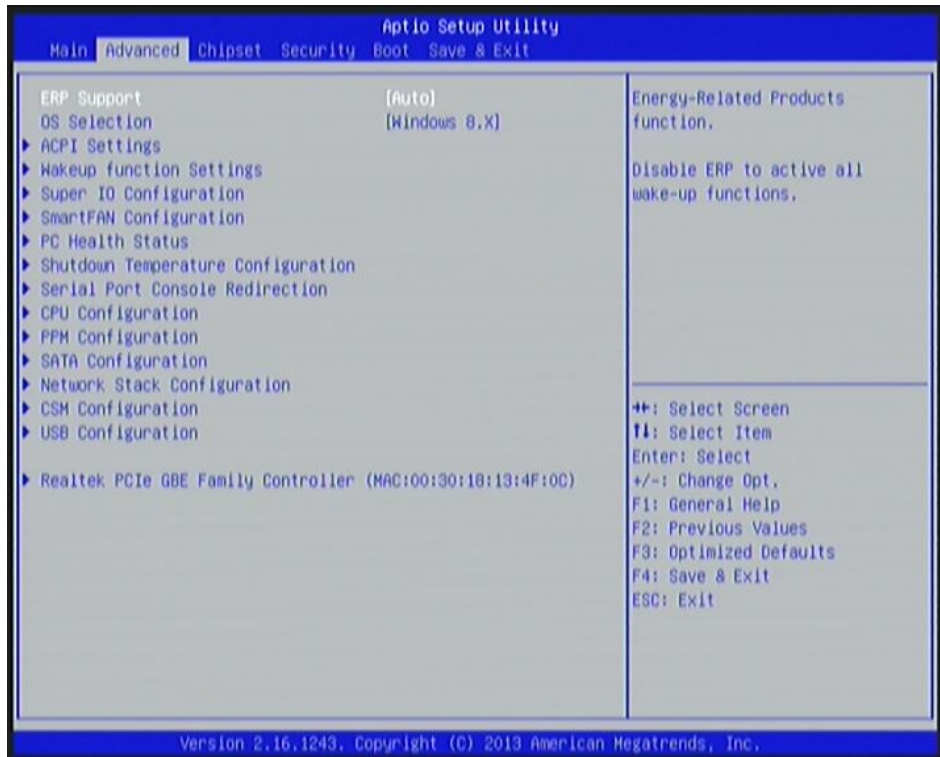

ERP Function

The optional settings: [Auto]; [Disabled].

This item should be set as [**Disabled**] if you wish to have all active wake-up functions.

OS Selection

The optional settings: [Windows 8.X]; [Windows 7].

▶ **ACPI Settings**

Press [Enter] to make settings for the following sub-item:

ACPI Settings

ACPI Sleep State

Use this item to select the highest ACPI sleep state the system will enter when the suspend button is pressed.

The optional settings are: [Suspend Disabled]; [S3 (Suspend to RAM)].

▶ **Wakeup Function Settings**

Press [Enter] to make settings for the following sub-items:

Wake System with Fixed Time

Use this item to enable or disable system wake on alarm event. When set as [Enabled], system will wake on the hour/min/sec specified.

PS2 KB/MS Wakeup

Use this item to enable or disable PS2 KB/MS wakeup from S3/S4/S5 state. This function is only supported when ERP function is disabled.

**This item will only show when 'ERP Support' is set as [Disabled].*

▶ **Super I/O Configuration**

Press [Enter] to make settings for the following sub-items:

Super IO Configuration

▶ **Serial Port 1 Configuration**

Press [Enter] to make settings for the following items:

Serial Port

Use this item to enable or disable serial port (COM).

Change Settings

Use this item to select an optimal setting for super IO device.

Transmission Mode Select

The optional settings are: [RS422]; [RS232]; [RS485].

Mode Speed Select

The optional settings are: [RS232/RS422/RS485=250kbps]; [RS232=1Mbps, RS422/RS485=10Mbps].

Serial Port FIFO Mode

The optional settings are: [16-Byte FIFO]; [32-Byte FIFO]; [64-Byte FIFO]; [128-Byte FIFO].

▶ **Serial Port 2 Configuration/ Serial Port 3 Configuration/ Serial Port 4 Configuration**

Press [Enter] to make settings for the following items:

Serial Port

Use this item to enable or disable serial port (COM).

Change Settings

Use this item to select an optimal setting for super IO device.

Serial Port FIFO Mode

The optional settings are: [16-Byte FIFO]; [32-Byte FIFO]; [64-Byte FIFO]; [128-Byte FIFO].

▶ **Parallel Port Configuration**

Press [Enter] to make settings for the following items:

Parallel Port

Use this item to enable or disable parallel port (LPT/LPTE).

Change Settings

Use this item to select an optimal setting for super IO device.

Device Mode

The optional settings are: [STD Printer Mode]; [SPP Mode]; [EPP-1.9 and SPP Mode]; [EPP-1.7 and SPP Mode]; [ECP Mode]; [ECP and EPP 1.9 Mode]; [ECP and EPP 1.7 Mode].

WatchDog Timer

Use this item to enable or disable WatchDog Timer Control. When set as [Enabled], the following sub-items shall appear:

WatchDog Timer Value

User can set a value in the range of 4 to 255.

WatchDog Timer Unit

The optional settings are: [Sec.]; [Min.].

WatchDog Wake-up Timer in ERP

This item support WDT wake-up while ERP function is set as [Enabled].

The optional settings are: [Enabled]; [Disabled].

When set as [Enabled], the following sub-items shall appear:

WatchDog Timer Value in ERP

User can set a value in the range of 10 to 4095.

WatchDog Timer Unit

The optional settings are: [Sec.]; [Min.].

ATX Power Emulate AT Power

This item support Emulate AT power function, MB power On/Off control by power supply. Use needs to select 'AT or ATX Mode' on MB jumper at first (ATX Mode & AT Mode Select).

Case Open Detect

This item controls detect case open function.
The optional settings are: [Enabled]; [Disabled].

▶ **SmartFan Configuration**

Press [Enter] to make settings for SmartFan Configuration:

CPUFAN / SYSFAN1/2 Smart Mode

When set as [Enabled], the following sub-items shall appear:

CPUFAN / SYSFAN1/2 Full-Speed Temperature

Use this item to set CPUFAN/SYSFAN1/2 full speed temperature. Fan will run at full speed when above this temperature.

CPUFAN / SYSFAN1/2 Full-Speed Duty

Use this item to set CPUFAN/SYSFAN1/2 full speed duty. Fan will run at full speed when above the pre-set duty.

CPUFAN / SYSFAN1/2 Idle-Speed Temperature

Use this item to set CPUFAN/SYSFAN1/2 idle speed temperature. Fan will run at idle speed when below this temperature.

CPUFAN / SYSFAN1/2 Idle-Speed Duty

Use this item to set CPUFAN/SYSFAN1/2 idle speed duty.. Fan will run at idle speed when below the pre-set duty.

▶ **PC Health Status**

Press [Enter] to view current hardware health status.

▶ **Shutdown Temperature Configuration**

Use this item to select system shutdown temperature.

The optional settings are: [Disabled]; [70C/158F]; [75C/167F]; [80C/176F]; [85C/185F].

▶ **Serial Port Consol Redirection**

Press [Enter] to make settings for serial port redirection settings:

COM1

Console Redirection

The optional settings are: [Enabled]; [Disabled].

When set as [Enabled], user can make further settings in:

▶ **Console Redirection Settings**

The settings specify how the host computer and the remote computer (which the user is using) will exchange data. Both computers should have the same or compatible settings.

Press [Enter] to make settings for the following sub-items.

Terminal Type

The optional settings are: [VT100]; [VT100+]; [VT-UTF8]; [ANSI].

Bits per second

The optional settings are: [9600]; [19200]; [38400]; [57600]; [115200].

Data Bits

The optional settings are: [7]; [8].

Parity

The optional settings are: [None]; [Even]; [Odd];[Mark]; [Space].

Stop Bits

The optional settings are: [1]; [2].

Flow Control

The optional settings are: [None]; [Hardware RTS/CTS].

VT-UTF8 Combo Key Support

The optional settings are: [Enabled]; [Disabled].

Recorder Mode

The optional settings are: [Enabled]; [Disabled].

Resolution 100x31

The optional settings are: [Enabled]; [Disabled].

Legacy OS Redirection Resolution

The optional settings are: [80x24]; [80x25].

Putty Keypad

The optional settings are: [VT100]; [LINUX]; [XTERMR6]; [SCO]; [ESCN]; [VT400].

Redirection After BIOS POST

The optional settings are: [Always Enable]; [BootLoader].

Serial Port for Out-of-Band Management

/Windows Emergency Management Services (EMS)

Console Redirection

The optional settings are: [Enabled]; [Disabled].

When set as [Enabled], user can make further settings in ‘Console Redirection Settings’:

▶ **Console Redirection Settings**

The settings specify how the host computer and the remote computer (which the user is using) will exchange data. Both computers should have the same or compatible settings.

Press [Enter] to make settings for the following sub-items.

Out-of-Band Mgmt Port

This item may or may not show up, depending on different configuration.

Terminal Type

The optional settings are: [VT100]; [VT100+]; [VT-UTF8]; [ANSI].

Bits per second

The optional settings are: [9600]; [19200]; [57600]; [115200].

Flow Control

The optional settings are: [None] ; [Hardware RTS/CTS]; [Software Xon/Xoff].

Data Bits

The default setting is: [8].

**This item may or may not show up, depending on different configuration.*

Parity

The default setting is: [None].

**This item may or may not show up, depending on different configuration.*

Stop Bits

The default setting is: [1].

**This item may or may not show up, depending on different configuration.*

▶ **CPU Configuration**

Press [Enter] to view current CPU configuration and make settings for the following sub-items:

Limit CPUID Maximum

The optional settings: [Disabled]; [Enabled].

This item should be set as [Disabled] for Windows XP.

Execute Disable Bit

The optional settings: [Disabled]; [Enabled].

Hardware Prefetcher

The optional settings are: [Disabled]; [Enabled].

Use this item to turn on/off the Mid Level Cache (L2) streamer prefetcher.

Adjacent Cache Line Prefetch

The optional settings are: [Disabled]; [Enabled].

Use this item to turn on/off prefetching of adjacent cache lines.

Intel Virtualization Technology

The optional settings: [Enabled]; [Disabled].

When set as [Enabled], a VMM can utilize the additional hardware capabilities provided by Vanderpool Technology.

Power Technology

The optional settings: [Disabled]; [Energy Efficient].

▶ **PPM Configuration**

Press [Enter] to make settings for PPM Configuration:

PPM Configuration:

EIST

The optional settings: [Enabled]; [Disabled].

Use this item to enable or disable Intel SpeedStep.

CPU C Status Report

Use this item to enable or disable CPU C status report to OS.

The optional settings: [Disabled]; [Enabled].

When set as [Enabled], the following sub-items shall appear:

Enhanced C state

Use this item to enable or disable CPU C state.

Max CPU C-state

The optional settings: [C7]; [C6]; [C1].

▶ **SATA Configuration**

Press [Enter] to make settings for the following sub-items:

SATA Configuration

SATA Port

The optional settings: [Disabled]; [Enabled].

SATA Mode

The optional settings are: [IDE Mode]; [AHCI Mode].

SATA Speed Support

The item is for user to set the maximum speed the SATA controller can support.

The optional settings are: [Gen1]; [Gen2].

SATA ODD Port

The optional settings are: [Port1 ODD]; [Port2 ODD]; [No ODD].

SATA Port1

The optional settings are: [Enabled]; [Disabled].

SATA Port2

The optional settings are: [Enabled]; [Disabled].

▶ **Network Stack Configuration**

Press [Enter] to go to '**Network Stack**' screen to make further settings.

Network Stack

The optional settings are: [Enabled]; [Disabled].

When set as [Enabled], the following sub-items shall appear:

Ipv4 PXE Support

The optional settings are: [Disabled]; [Enabled].

Use this item to enable Ipv4 PXE Boot Support. When set as [Disabled], Ipv4 boot optional will not be created.

Ipv6 PXE Support

The optional settings are: [Disabled]; [Enabled].

Use this item to enable Ipv6 PXE Boot Support. When set as [Disabled], Ipv4 boot optional will not be created.

PXE boot wait time

Use this item to set wait time to press [ESC] key to abort the PXE boot.

▶ **CSM Configuration**

Press [Enter] to make settings for the following sub-items:

Compatibly Support Module Configuration

Option ROM Message

The optional settings are: [Force BIOS]; [Keep Current].

INT19 Trap Response

The optional settings are: [Immediate]; [Postponed].

Option ROM execution order

Network

This item controls the execution of UEFI and legacy PXE OpROM.

The optional settings are: [Do not launch]; [UEFI only]; [Legacy only].

Storage

This item controls the execution of UEFI and Legacy Storage OpROM.

The optional settings are: [Do not launch]; [UEFI only]; [Legacy only]; [Legacy first]; [UEFI first].

Other PCI devices

This item determines OpROM execution policy for devices other than Network, storage or video.

The optional settings are: [UEFI first]; [Legacy Only].

▶ **USB Configuration**

Press [Enter] to make settings for the following sub-items:

USB Configuration

Legacy USB Support

The optional settings are: [Enabled]; [Disabled]; [Auto].

[Enabled]: To enable legacy USB support.

[Disabled]: To keep USB devices available only for EFI specification,

[Auto]: To disable legacy support if no USB devices are connected.

XHCI Hand-off

This is a workaround for OSeS without XHCI hand-off support. The XHCI ownership change should be claimed by XHCI driver.

The optional settings are: [Enabled]; [Disabled].

EHCI Hand-off

This is a workaround for OSeS without EHCI hand-off support. The EHCI ownership change should be claimed by EHCI driver.

The optional settings are: [Disabled]; [Enabled].

USB Mass Storage Driver Support

The optional settings are: [Disabled]; [Enabled].

USB hardware delay and time-outs:

USB Transfer time-out

Use this item to set the time-out value for control, bulk, and interrupt transfers.

The optional settings are: [1 sec]; [5 sec]; [10 sec]; [20 sec].

Device reset time-out

Use this item to set USB mass storage device start unit command time-out.

The optional settings are: [10 sec]; [20 sec]; [30 sec]; [40 sec].

Device power-up delay

Use this item to set maximum time the device will take before it properly reports itself to the host controller. 'Auto' uses default value: for a root port it is 100 ms, for

a hub port the delay is taken from hub descriptor.

The optional settings: [Auto]; [Manual].

Select [Manual] you can set value for the following sub-item: '**Device Power-up delay in seconds**'.

Device Power-up delay in seconds

The delay range is from 1 to 40 seconds, in one second increments.

▶ **Reltek PCIe GBE Family Controller (MAC:XX:XX:XX:XX:XX:XX)**

Use this item to get driver information and configure Realtek ethernet controller parameter.

3-8 Chipset Menu

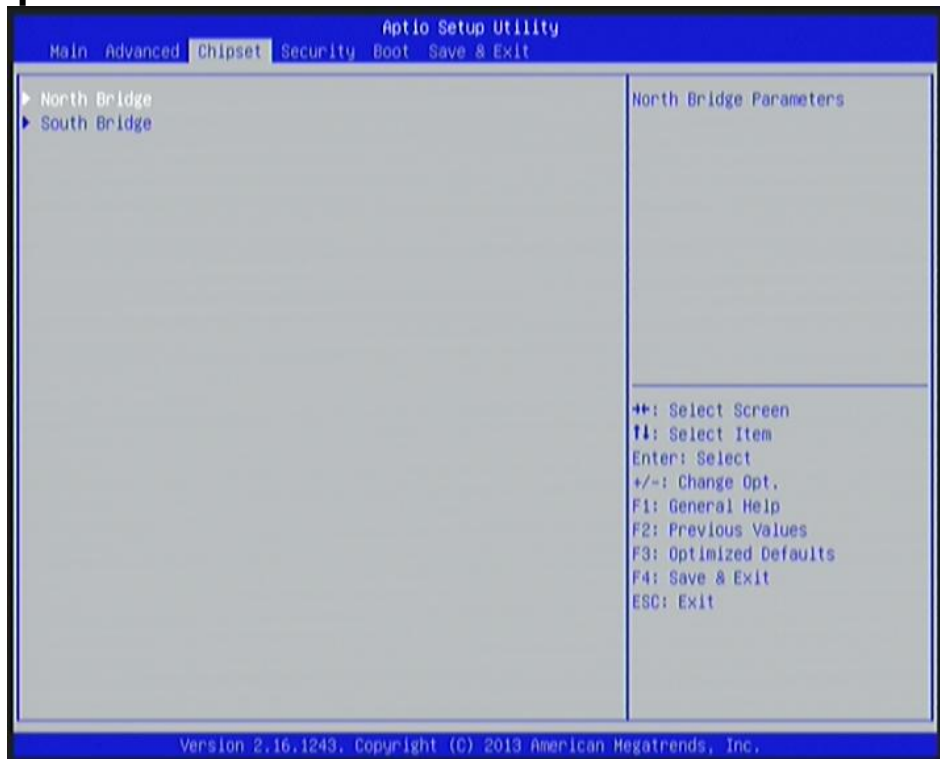

▶ **North Bridge**

Press [Enter] to view current using memory information and make settings for the following sub-items:

Intel IGD Configuration

IGD Turbo Enable

The optional settings are: [Enabled]; [Disabled].

Spread Spectrum Clock

The optional settings are: [Enabled]; [Disabled].

IGD Boot Type

Use this item to select preference display interface used when system boot. The optional settings are: [DVI/CRT]; [CRT]; [HDMI/DVI].

Active LFP

The optional settings are: [Disabled]; [Enabled].

[Disable]: VBIOS does not enable LVDS.

[Enable]: VBIOS enable LVDS driver by integrated encoder.

**When set as 'Enabled', user can make further settings in 'LVDS Panel Type'*

LVDS Panel Type

Use this item to select LVDS panel resolution.

The optional setting are: [640 x 480 18bit Single]; [800 x 480 18bit Single]; [800x 600 18bit Single]; [1024 x 600 18bit Single]; [1024 x 768 24bit Single]; [1280 x 720 18bit Single]; [1280 x 1024 24bit Dual]; [1366 x 768 18bit Single]; [1366 x 768 24bit Single]; [1440 x 900 18bit Dual]; [1440 x 900 24bit Dual]; [1400 x 1050 24bit Dual]; [1600 x 900 24bit Dual]; [1680 x 1050 24bit Dual]; [1600 x 1200 24bit Dual]; [1920 x 1080 24bit Dual].

▶ **South Bridge**

Press [Enter] to further setting USB device configuration.

▶ **Azalia HD Audio**

Press [Enter] to further setting USB device configuration.

Audio Configuration

Audio Controller

The optional settings are: [Disabled]; [Enabled]

.Azalia Internal HDMI Codec

Use this item to enable or disable internal HDMI codec for Azalia.

The optional settings are: [Disabled]; [Enabled].

▶ **USB Configuration**

Press [Enter] to make settings for the following sub-items:

USB Configuration

USB 3.0 Support

The optional settings are: [Auto]; [Disabled].

USB 3.0 Link Power Management

The optional settings are: [Enabled]; [Disabled].

USB 2.0 Support

The optional settings are: [Auto]; [Disabled].

**This item may or may not show up, depending on different configuration.*

PCI-E Slot Speed

The optional settings are: [Auto]; [Gen2]; [Gen1].

Onboard Lan1 Controller

The optional settings are: [Enabled]; [Disabled].

Asmedia USB 3.0 Controller

The optional settings are: [Enabled]; [Disabled].

Mini PCIE

The optional settings are: [Enabled]; [Disabled].

Speed

The optional settings are: [Auto]; [Gen2]; [Gen1].

Restore AC Power Loss

Use this item to select AC power state when power is re-applied after a power failure. The optional settings are: [Power Off]; [Power On]; [Last State].

3-9 Security Menu

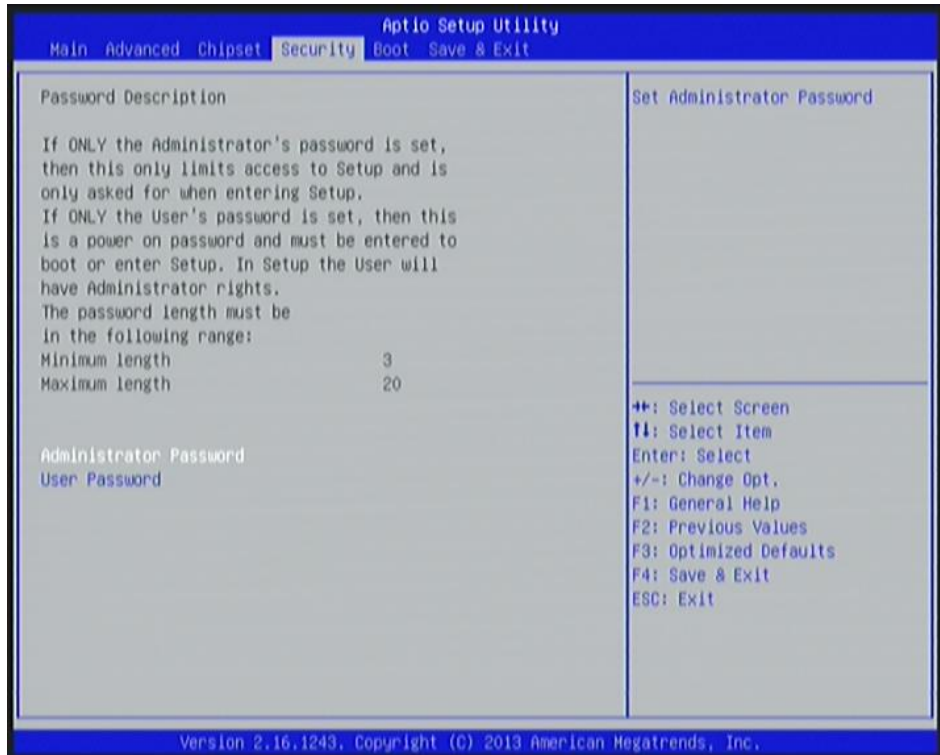

Security menu allow users to change administrator password and user password settings.

3-10 Boot Menu

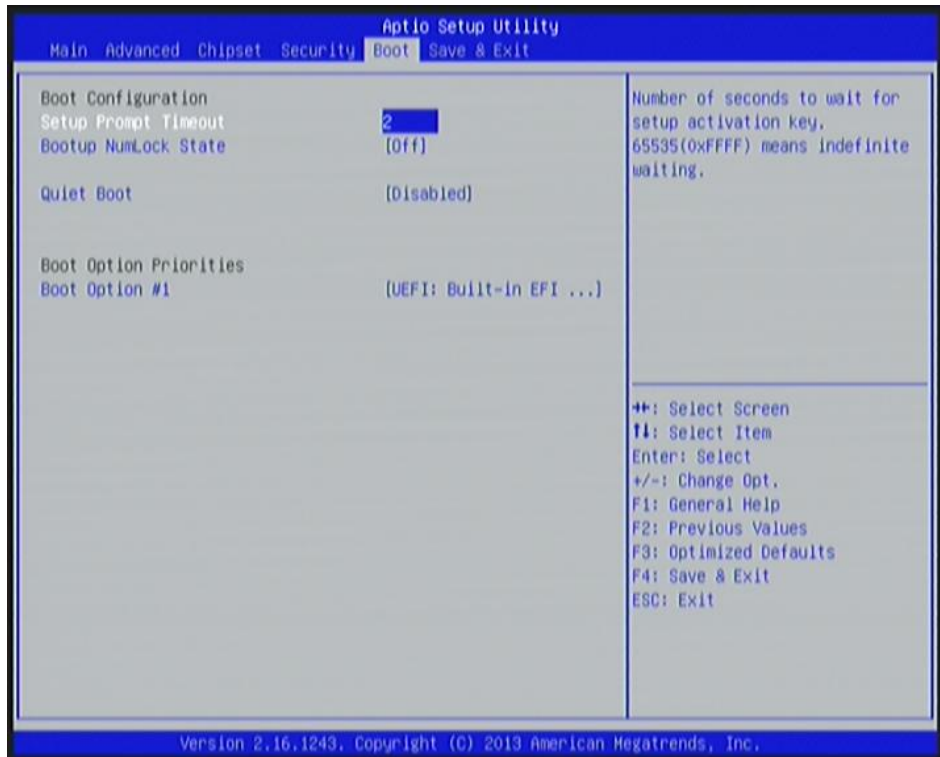

Boot Configuration

Setup Prompt Timeout

Use this item to set number of seconds to wait for setup activation key.

Bootup Numlock State

Use this item to select keyboard numlock state.

The optional settings are: [On]; [Off].

Quiet Boot

The optional settings are: [Disabled]; [Enabled].

Boot Option Priorities

Boot Option

The optional settings are: [UEFI: Built-in EFI Shell]; [Disabled].

3-11 Save & Exit Menu

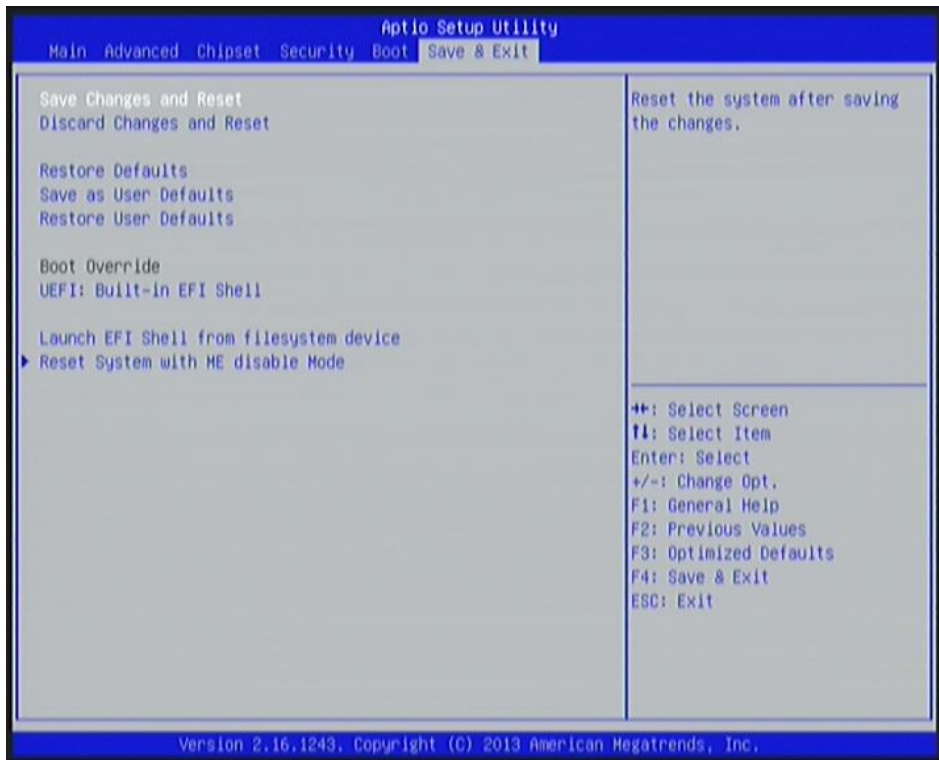

Save Changes and Reset

This item allows user to reset the system after saving the changes.

Discard Changes and Reset

This item allows user to reset the system without saving any changes.

Restore Defaults

Use this item to restore /load default values for all the setup options.

Save as User Defaults

Use this item to save the changes done so far as user defaults.

Restore User Defaults

Use this item to restore defaults to all the setup options.

Launch EFI Shell from filesystem device

Use this item to launch EFI shell application (shell.efi) from one of the available filesystem device.

Reset System with ME disable Mode

Press [Enter] for ME to run into the temporary disable mode. Ignore if ME Ignition FM.